

PART. NO	OD	ID	T/L
30-6.3-1	30	6.3	1.0
30-6.3-1.5	30	6.3	1.5
30-6.3-2	30	6.3	2.0
30-6.3-3	30	6.3	3.0
30-6.3-4	30	6.3	4.0
30-6.3-5	30	6.3	5.0
30-6.3-6	30	6.3	6.0
30-6.3-7.5	30	6.3	7.5
30-6.3-8	30	6.3	8.0
30-6.3-10	30	6.3	10.0
30-6.3-12.5	30	6.3	12.5
30-6.3-15	30	6.3	15.0
30-6.3-20	30	6.3	20.0
30-6.3-25	30	6.3	25.0
30-8.3-1	30	8.3	1.0
30-8.3-1.5	30	8.3	1.5
30-8.3-2	30	8.3	2.0
30-8.3-3	30	8.3	3.0
30-8.3-4	30	8.3	4.0
30-8.3-5	30	8.3	5.0
30-8.3-6	30	8.3	6.0
30-8.3-7.5	30	8.3	7.5
30-8.3-8	30	8.3	8.0
30-8.3-10	30	8.3	10.0
30-8.3-12.5	30	8.3	12.5
30-8.3-15	30	8.3	15.0
30-8.3-20	30	8.3	20.0
30-8.3-25	30	8.3	25.0
30-10.4-1	30	10.4	1.0
30-10.4-1.5	30	10.4	1.5
30-10.4-2	30	10.4	2.0
30-10.4-3	30	10.4	3.0
30-10.4-4	30	10.4	4.0
30-10.4-5	30	10.4	5.0
30-10.4-6	30	10.4	6.0
30-10.4-7.5	30	10.4	7.5
30-10.4-8	30	10.4	8.0
30-10.4-10	30	10.4	10.0
30-10.4-12.5	30	10.4	12.5
30-10.4-15	30	10.4	15.0

PART. NO	OD	ID	T/L
30-10.4-20	30	10.4	20.0
30-10.4-25	30	10.4	25.0
30-12.8-1	30	12.8	1.0
30-12.8-1.5	30	12.8	1.5
30-12.8-2	30	12.8	2.0
30-12.8-3	30	12.8	3.0
30-12.8-4	30	12.8	4.0
30-12.8-5	30	12.8	5.0
30-12.8-6	30	12.8	6.0
30-12.8-7.5	30	12.8	7.5
30-12.8-8	30	12.8	8.0
30-12.8-10	30	12.8	10.0
30-12.8-12	30	12.8	12.0
30-12.8-15	30	12.8	15.0
30-12.8-20	30	12.8	20.0
30-12.8-25	30	12.8	25.0
30-16.5-1	30	16.5	1.0
30-16.5-1.5	30	16.5	1.5
30-16.5-2	30	16.5	2.0
30-16.5-3	30	16.5	3.0
30-16.5-4	30	16.5	4.0
30-16.5-5	30	16.5	5.0
30-16.5-6	30	16.5	6.0
30-16.5-7.5	30	16.5	7.5
30-16.5-8	30	16.5	8.0
30-16.5-10	30	16.5	10.0
30-16.5-12.5	30	16.5	12.5
30-16.5-15	30	16.5	15.0
30-16.5-20	30	16.5	20.0
30-16.5-25	30	16.5	25.0
30-20.5-1	30	20.5	1.0
30-20.5-1.5	30	20.5	1.5
30-20.5-2	30	20.5	2.0
30-20.5-3	30	20.5	3.0
30-20.5-4	30	20.5	4.0
30-20.5-5	30	20.5	5.0
30-20.5-6	30	20.5	6.0
30-20.5-7.5	30	20.5	7.5
30-20.5-8	30	20.5	8.0
30-20.5-10	30	20.5	10.0

PART. NO	OD	ID	T/L
30-20.5-12.5	30	20.5	12.5
30-20.5-15	30	20.5	15.0
30-20.5-20	30	20.5	20.0
30-20.5-25	30	20.5	25.0

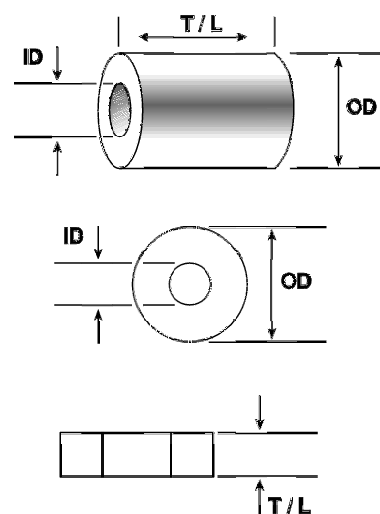

Stock components available in:

- Nylon 6
- H.D.P.E. (High Density Polyethylene)
- Colours - Natural and Black others available on request
- Intermediate lengths on request
- Specification of materials on request

Custom Mouldings:

- Please send drawings or samples for quotation



Cert. No.: FM40736