

PART. NO	OD	ID	T/L
40-6.3-1	40	6.3	1.0
40-6.3-1.5	40	6.3	1.5
40-6.3-2	40	6.3	2.0
40-6.3-3	40	6.3	3.0
40-6.3-4	40	6.3	4.0
40-6.3-5	40	6.3	5.0
40-6.3-6	40	6.3	6.0
40-6.3-7.5	40	6.3	7.5
40-6.3-8	40	6.3	8.0
40-6.3-10	40	6.3	10.0
40-6.3-12.5	40	6.3	12.5
40-6.3-15	40	6.3	15.0
40-6.3-20	40	6.3	20.0
40-6.3-25	40	6.3	25.0
40-8.3-1	40	8.3	1.0
40-8.3-1.5	40	8.3	1.5
40-8.3-2	40	8.3	2.0
40-8.3-3	40	8.3	3.0
40-8.3-4	40	8.3	4.0
40-8.3-5	40	8.3	5.0
40-8.3-6	40	8.3	6.0
40-8.3-5	40	8.3	5.0
40-8.3-8	40	8.3	8.0
40-8.3-10	40	8.3	10.0
40-8.3-12.5	40	8.3	12.5
40-8.3-15	40	8.3	15.0
40-8.3-20	40	8.3	20.0
40-8.3-25	40	8.3	25.0
40-10.4-1	40	10.4	1.0
40-10.4-1.5	40	10.4	1.5
40-10.4-2	40	10.4	2.0
40-10.4-3	40	10.4	3.0
40-10.4-4	40	10.4	4.0
40-10.4-5	40	10.4	5.0
40-10.4-6	40	10.4	6.0
40-10.4-7.5	40	10.4	7.5
40-10.4-8	40	10.4	8.0
40-10.4-10	40	10.4	10.0
40-10.4-12.5	40	10.4	12.5
40-10.4-15	40	10.4	15.0

PART. NO	OD	ID	T/L
40-10.4-20	40	10.4	20.0
40-10.4-25	40	10.4	25.0
40-12.8-1	40	12.8	1.0
40-12.8-1.5	40	12.8	1.5
40-12.8-2	40	12.8	2.0
40-12.8-3	40	12.8	3.0
40-12.8-4	40	12.8	4.0
40-12.8-5	40	12.8	5.0
40-12.8-6	40	12.8	6.0
40-12.8-7.5	40	12.8	7.5
40-12.8-8	40	12.8	8.0
40-12.8-10	40	12.8	10.0
40-12.8-12.5	40	12.8	12.5
40-12.8-15	40	12.8	15.0
40-12.8-20	40	12.8	20.0
40-12.8-25	40	12.8	25.0
40-16.5-1	40	16.5	1.0
40-16.5-1.5	40	16.5	1.5
40-16.5-2	40	16.5	2.0
40-16.5-3	40	16.5	3.0
40-16.5-4	40	16.5	4.0
40-16.5-5	40	16.5	5.0
40-16.5-6	40	16.5	6.0
40-16.5-7.5	40	16.5	7.5
40-16.5-8	40	16.5	8.0
40-16.5-10	40	16.5	10.0
40-16.5-12.5	40	16.5	12.5
40-16.5-15	40	16.5	15.0
40-16.5-20	40	16.5	20.0
40-16.5-25	40	16.5	25.0
40-20.5-1	40	20.5	1.0
40-20.5-1.5	40	20.5	1.5
40-20.5-2	40	20.5	2.0
40-20.5-3	40	20.5	3.0
40-20.5-4	40	20.5	4.0
40-20.5-5	40	20.5	5.0
40-20.5-6	40	20.5	6.0
40-20.5-7.5	40	20.5	7.5
40-20.5-8	40	20.5	8.0
40-20.5-10	40	20.5	10.0

PART. NO	OD	ID	T/L
40-20.5-12.5	40	20.5	12.5
40-20.5-15	40	20.5	15.0
40-20.5-20	40	20.5	20.0
40-20.5-25	40	20.5	25.0

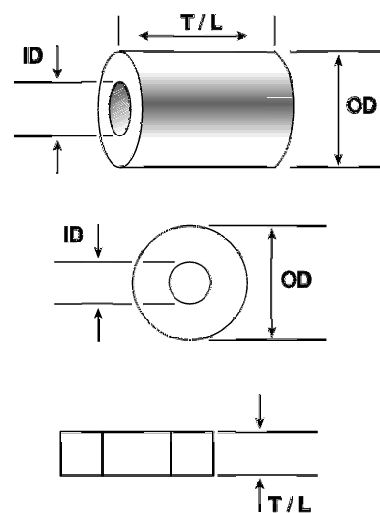

Stock components available in:

- Nylon 6
- H.D.P.E. (High Density Polyethylene)
- Colours - Natural and Black others available on request
- Intermediate lengths on request
- Specification of materials on request

Custom Mouldings:

- Please send drawings or samples for quotation



Cert. No.: FM40736