

PART. NO	OD	ID	T/L
6-3.2-1	6	3.2	1.0
6-3.2-1.5	6	3.2	1.5
6-3.2-2	6	3.2	2.0
6-3.2-3	6	3.2	3.0
6-3.2-4	6	3.2	4.0
6-3.2-5	6	3.2	5.0
6-3.2-6	6	3.2	6.0
6-3.2-7.5	6	3.2	7.5
6-3.2-8	6	3.2	8.0
6-3.2-10	6	3.2	10.0
6-3.2-12.5	6	3.2	12.5
6-3.2-15	6	3.2	15.0
6-3.2-20	6	3.2	20.0
6-3.2-25	6	3.2	25.0
6-4.3-1	6	4.3	1.0
6-4.3-1.5	6	4.3	1.5
6-4.3-2	6	4.3	2.0
6-4.3-3	6	4.3	3.0
6-4.3-4	6	4.3	4.0
6-4.3-5	6	4.3	5.0
6-4.3-6	6	4.3	6.0
6-4.3-7.5	6	4.3	7.5
6-4.3-8	6	4.3	8.0
6-4.3-10	6	4.3	10.0
6-4.3-12.5	6	4.3	12.5
6-4.3-15	6	4.3	15.0
6-4.3-20	6	4.3	20.0
6-4.3-25	6	4.3	25.0

PART. NO	OD	ID	T/L
8-3.2-1	8	3.2	1.0
8-3.2-1.5	8	3.2	1.5
8-3.2-2	8	3.2	2.0
8-3.2-3	8	3.2	3.0
8-3.2-4	8	3.2	4.0
8-3.2-5	8	3.2	5.0
8-3.2-6	8	3.2	6.0
8-3.2-7.5	8	3.2	7.5
8-3.2-8	8	3.2	8.0
8-3.2-10	8	3.2	10.0
8-3.2-12.5	8	3.2	12.5
8-3.2-15	8	3.2	15.0
8-3.2-20	8	3.2	20.0
8-3.2-25	8	3.2	25.0
8-4.3-1	8	4.3	1.0
8-4.3-1.5	8	4.3	1.5
8-4.3-2	8	4.3	2.0
8-4.3-3	8	4.3	3.0
8-4.3-4	8	4.3	4.0
8-4.3-5	8	4.3	5.0
8-4.3-6	8	4.3	6.0
8-4.3-7.5	8	4.3	7.5
8-4.3-8	8	4.3	8.0
8-4.3-10	8	4.3	10.0
8-4.3-12.5	8	4.3	12.5
8-4.3-15	8	4.3	15.0
8-4.3-20	8	4.3	20.0
8-4.3-25	8	4.3	25.0
8-5.3-1	8	5.3	1.0
8-5.3-1.5	8	5.3	1.5
8-5.3-2	8	5.3	2.0
8-5.3-3	8	5.3	3.0
8-5.3-4	8	5.3	4.0
8-5.3-5	8	5.3	5.0
8-5.3-6	8	5.3	6.0
8-5.3-7.5	8	5.3	7.5
8-5.3-8	8	5.3	8.0
8-5.3-10	8	5.3	10.0
8-5.3-12.5	8	5.3	12.5
8-5.3-15	8	5.3	15.0
8-5.3-20	8	5.3	20.0
8-5.3-25	8	5.3	25.0

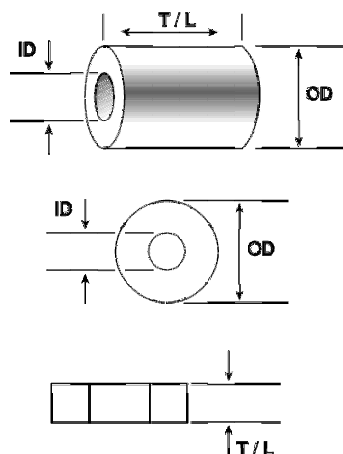
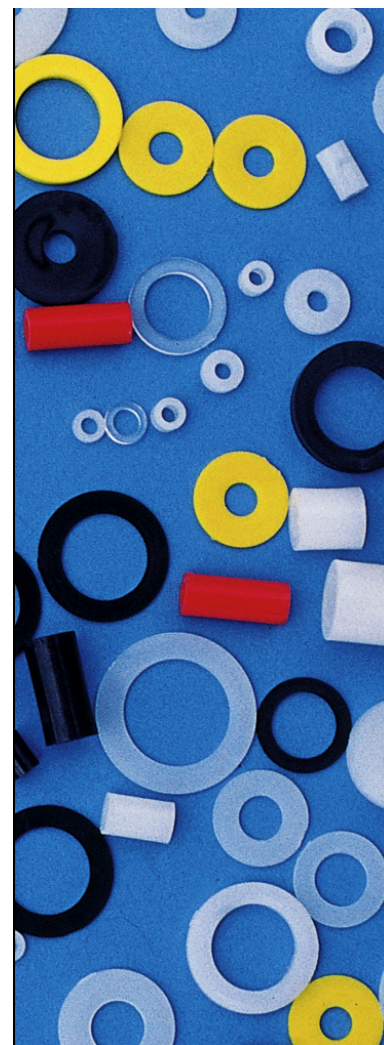

Stock components available in:

- Nylon 6
- H.D.P.E. (High Density Polyethylene)
- Colours - Natural and Black others available on request
- Intermediate lengths on request
- Specification of materials on request

Custom Mouldings:

- Please send drawings or samples for quotation